



WHEEL REMOVAL TROLLEY 500KG ADJUSTABLE WIDTH

MODEL NO: **W508T.V3**

Thank you for purchasing a Sealey product. Manufactured to a high standard, this product will, if used according to these instructions, and properly maintained, give you years of trouble free performance.

IMPORTANT: PLEASE READ THESE INSTRUCTIONS CAREFULLY. NOTE THE SAFE OPERATIONAL REQUIREMENTS, WARNINGS & CAUTIONS. USE THE PRODUCT CORRECTLY AND WITH CARE FOR THE PURPOSE FOR WHICH IT IS INTENDED. FAILURE TO DO SO MAY CAUSE DAMAGE AND/OR PERSONAL INJURY AND WILL INVALIDATE THE WARRANTY. KEEP THESE INSTRUCTIONS SAFE FOR FUTURE USE.



Refer to instruction manual



Wear protective gloves



Wear safety footwear

1. SAFETY

- ✓ This trolley is designed for the removal, transportation and installation of vehicle wheels and should be used for no other purpose.
- ✓ Always lower, centre and chain the wheel before attempting to move trolley.
- ✓ Only use the trolley on firm, level, unobstructed surfaces which are capable of supporting the trolley and wheel.
- ✗ **DO NOT** overload the trolley - maximum capacity is 500kg.
- ✗ **DO NOT** ride or allow others to ride on the trolley.
- ✗ **DO NOT** use on tarmac. The trolley must only be used on a concrete surface.
- ✓ Replace or repair damaged parts. Use only recommended parts. Unauthorised parts may be dangerous and will invalidate the warranty.
- ✓ Use a qualified person to lubricate and maintain the trolley. **DO NOT** use brake fluid to top-up hydraulic unit. Use Sealey hydraulic oil only.
- ☐ **WARNING!** Failure to comply with these instructions may result in loss of load, damage to trolley or other property and/or personal injury.

2. INTRODUCTION

Suitable for changing wheels and tyres on the very largest vehicles. 8 Position adjustable roller width ranging from 440 to 780mm giving greater flexibility. Load arms incorporate smooth roller action sleeves allowing wheel to be rotated for lining up on studs. Foot operated hydraulic mechanism with dead man's control release. Mounted on two swivel and two fixed castors for stability and easy manoeuvrability. Supplied with safety chain.

3. SPECIFICATION

Model no: **W508T.V3**
Maximum lifting capacity: 500kg
Minimum lifting height: 50mm
Maximum lifting height: 640mm
Width between rollers: 440, 496, 560, 610, 668, 724, 780mm
Roller length: 620mm

4. ASSEMBLY

Note: Numbers used refer to the parts diagram. The trolley should be assembled by at least 2 people.

- 4.1. Attach upright posts (13) to base beam (39), ensuring that the holes at the top for attaching the handle (28) are rearward facing. Secure each of the the posts with 3 bolts (2 x 14, and 15), nuts (22) and washers (2 and 20), making sure the longer bolts (15) are fitted horizontally.
- 4.2. Next place the jack (26) onto the base beam in between the brackets and secure with screws (9). Make sure foot pedal (fig.2C) is facing rearwards.
- 4.3. Slide the lifting bracket (31) over the upright posts (11), attach the top of the hydraulic ram to the top bracket on the lifting frame using a pin (27) washer (6) and split pin (8).
- 4.4. Slot the support beams (3) into the front brackets on the lifting bracket (31), line up the holes in the bracket with the holes in the support beams (3) and slide the axle (7) through, secure at each end with washer (6) and split pin (8).
- 4.5. Attach the handle (28) to the top of the upright posts (13) using bolts (33) and washers (34).
- 4.6. Fit the safety chain (32). Fix hooks (10) through columns (11) using nut (9). Hook chain (32) onto hooks (10).

5. OPERATION

- ☐ **WARNING!** Ensure that the vehicle to be worked on is safely supported on axle stands.
- 5.1. Before first use: 1) Oil all moving parts. 2) With lifting frame (fig.2A) at lowest point check hydraulic oil level by removing filler plug (fig.2B). Oil should be at bottom of filler hole. Top up, or allow to drain, as necessary and replace non vented transit plug with the vented plug, see fig.3.

5.2. LIFTING

- 5.2.1. Centre the trolley around the wheel, as close in as possible, and raise the lifting frame by operating the foot pedal (fig.2C).

5.3. LOWERING

5.3.1. Turn release valve (fig.2D) to lower lifting frame. Keep feet and hands away from the frame whilst it descends.

5.4. MOVEMENT

5.4.1. Before moving the laden trolley ensure that the wheel is centred on the rollers and restrained by the safety chain (fig.2E) and that the lifting frame is as low as possible whilst still allowing clearance between tyre and floor.

5.5. FRAME WIDTH

5.5.1. The lifting frame rollers can be set to these widths; 440, 496, 560, 610, 668, 724, 780mm. Each roller has to be lifted individually by its outer end so it hinges upwards (see fig.1.1). When the roller bracket is clear of its locking position, slide it along its hinge pin (fig.1.2) and lower it into the alternative locking positions.

6. MAINTENANCE

6.1. **Daily:** Check for damage and oil leaks. **Monthly:** Oil moving parts and grease pedal-to-piston faces. Check for abnormal wear and tear.

❑ **WARNING! DO NOT** use brake fluid, or any fluid other than hydraulic jack oil as this may cause serious damage to the jack and will invalidate the warranty!

6.2. With lifting frame at lowest point, check hydraulic oil level by removing filler plug (fig.2B). Level should be at bottom of filler hole. Top up, or allow to drain, as necessary. Replace plug.

7. FAULT FINDING

7.1. Lifting frame does not reach full height - low oil level, check and fill (see 5.1.).

7.2. Foot pump ineffective - oil level too high, check and drain (see 5.1.)

▲ **IMPORTANT: NO RESPONSIBILITY IS ACCEPTED FOR INCORRECT USE OF THIS PRODUCT.**

Hydraulic products are only repaired by local service agents. We have service/repair agents in all parts of the UK. **DO NOT** return the trolley to us. Please telephone us on 01284 757500 to obtain the address and 'phone number of your local agent. If trolley is under guarantee contact your local Sealey dealer.

De-commissioning the Jack

Should the jack become completely unserviceable and require disposal, draw off the oil into an approved container and dispose of the jack and the oil according to local regulations.

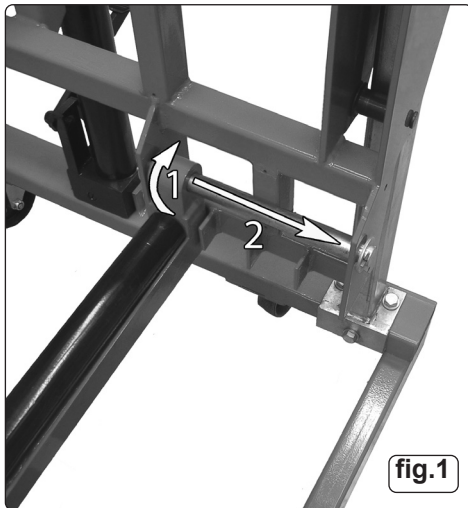
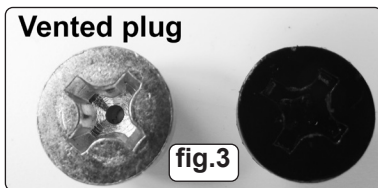

fig.1



Vented plug

fig.3

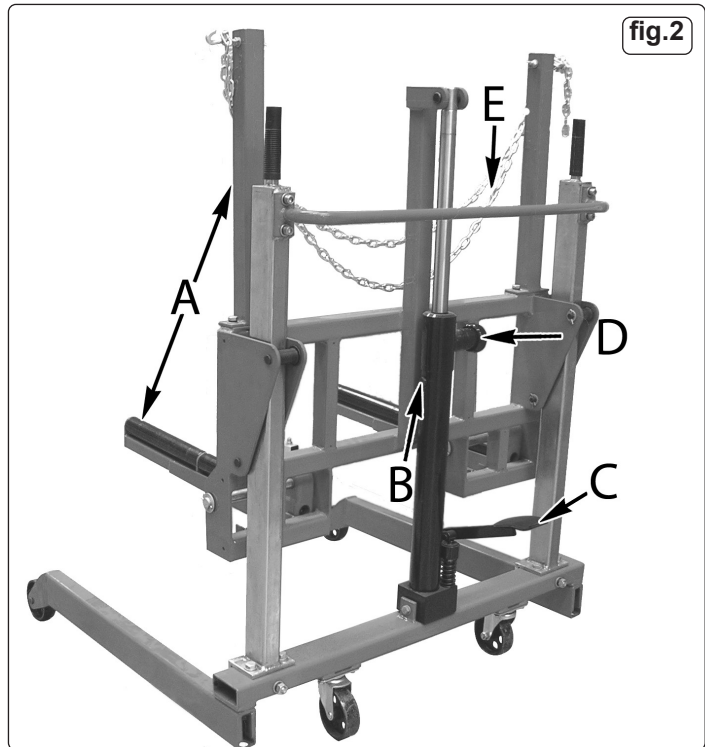

fig.2



ENVIRONMENT PROTECTION

Recycle unwanted materials instead of disposing of them as waste. All tools, accessories and packaging should be sorted, taken to a recycling centre and disposed of in a manner which is compatible with the environment.

When the product becomes completely unserviceable and requires disposal, drain any fluids (if applicable) into approved containers and dispose of the product and fluids according to local regulations.



REGISTER YOUR PURCHASE HERE

NOTE: It is our policy to continually improve products and as such we reserve the right to alter data, specifications and component parts without prior notice.

IMPORTANT: No Liability is accepted for incorrect use of this product.

WARRANTY: Guarantee is 12 months from purchase date, proof of which is required for any claim.

Jack Sealey Ltd t/a Sealey Group, Kempson Way, Suffolk Business Park, Bury St Edmunds, Suffolk, IP32 7AR UK

Jack Sealey (EU) Ltd t/a Sealey Group, Farney Street, Carrickmacross, Co. Monaghan, A81 PK68 Ireland

Tel: 01284 757500 • Email: sales@sealey.co.uk • Web: www.sealey.co.uk